



LFC™_3B Level Control Valve

Overview:

The LFC™_3B Level control valves are based on the same design as the LFC™_3B pressure regulating valve. Using a float ball to actuate the LFC™_3B level control valve is more cost effective than using electrical actuators to perform the same function. The upstream water hydraulic power is used to actuate the LFC™_3B level control valve. The speed of the valve can be adjusted to any desired speed fairly quickly and easily. The LFC™_3B Level control valve can be installed in remote locations where there is no access to electrical power. The LFC™_3B Level control valve has been developed to present a robust, simple and cost-effective low pressure (up to 2.5 MPa / 363 Psi) solution to fluid handling issues in any industrial sector.

Low Maintenance Requirement:

All the moving parts of LFC™_3B Level control valve are manufactured from stainless steel which increases reliability and durability. The LFC™_3B requires minimal maintenance, the majority of which, can be conducted with the valve remaining in situ.

Materials of Construction & Dimensions:

Part Name	Material Specification	Face To Face Dimensions		
		Valve size	Face to face #150	
		Unit	(mm)	(Inch)
Body	Coasting - Ductile iron			
Body seat	431 / 304 S/ Steel			
Plug	431 / 304 S/ Steel	DN50 / 2"	203	7.99
V-Port or Seat holder	431 / 304 S/ Steel	DN80 / 3"	241	9.49
Shaft	431 / 304 S/ Steel	DN100 / 4"	292	11.50
Piston	431 / 304 S/ Steel	DN150 / 6"	356	14.02
Plug seat	Polyurethane	DN200 / 8"	495	19.49
Sleeve	431 / 304 S/ Steel	DN250 / 10"	622	24.49
Sleeve Holder	Ductile iron	DN300 / 12"	699	27.52
Cylinder	431 / 304 S/ Steel	DN350 / 14"	787	30.98
Cylinder holder	Ductile iron	DN400 / 16"	914	35.98
Cylinder cover	Ductile iron			
Hoses	Single braided			

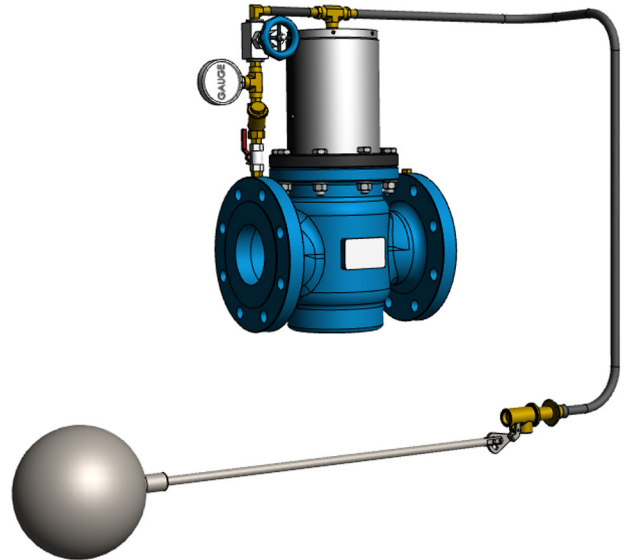

Simplicity:

The LFC™_3B Level control valve is designed to minimize wearing parts and in effect only has one moving part called the plug assembly. The plug assembly is a piston that is engineered to be un- balanced. The un- balanced plug uses the inline fluid pressure to remove the influence of differential pressure on operating torque. As such, the valve operating torque is the torque required to overcome the sum of the friction forces generated between the valve body, seals and the cylinder plus the weight of the plug (depending on the installation configuration). This torque requirement is not affected by inline pressure variants and therefore makes these valves extremely good for actuation applications as well as for isolation valves where manual operation is required. Removal of gearboxes reduces maintenance requirements and improves troubleshooting times. The valve uses a float ball valve to operate and it is simple in comparison with an electrical actuator. The LFC™_3B Level control valve can easily be fitted with limit switches to give open and closed indication.

Low Operating Torque:

The LFC™_3B Level control valves are hydrostatically un-balanced to enable easy opening and closing at any pressure and differential conditions. It does not require the use of a gearbox or by-pass valve to balance pressure between the inlet and outlet.

Valve Sizing

Please consult with Hydromine for clarification of correct sizing for your requirements.





LFC™_3B Level Control Valve

Flow Rates:

Flow (l/sec)	5	10	25	40	50	100	150	200	250	300	350	400
Pressure Drop (kPa)	DN50	47	94									
	DN80	17	34	86								
	DN100		23	57	79							
	DN150			26	36	51	102					
	DN200					28	56	84	112			
	DN250						37	55	73	91	112	
	DN300						26	37	50	63	75	90
Flow US gallon/ min	79.25	158.50	396.26	634.01	792.52	1585.03	2377.55	3170.06	3962.575	4755.09	5547.605	6340.12
Pressure Drop (psi)	2"	6.82	13.63									
	3"	2.47	4.93	12.47								
	4"		3.34	8.27	11.46							
	6"			3.77	5.22	7.4	14.79					
	8"					4.06	8.12	12.18	16.24			
	10"						5.37	7.98	10.59	13.2	16.24	
	12"						3.77	5.37	7.25	9.14	10.88	13.05

Plug Assembly, V-Port And Dealing With Cavitation:

Closed Position

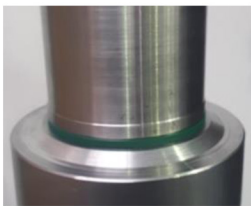

5% Open Position

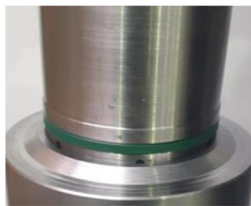

12% Open Position

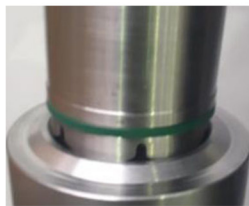

30% Open Position

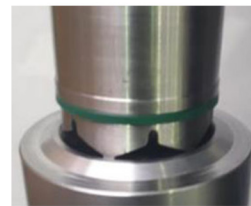

40% Open Position

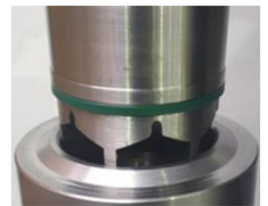

As displayed, the LFC™_3B level control valve plug assembly and movements.

Closed Position: Shows the plug assembly on the body seat in a fully closed valve position.

5% Open Position: Shows the plug assemble in a 5% open position. It can clearly be seen that only the top of the V-Port opens up and creates a flow path. This reduces cavitation and helps with fine control at low flow conditions.

12% Open Position: Shows the plug assembly in the 12% open position. Now it can be observed how the V-Port moved away from the seat and the openings are increasing proportionally. At this point the top of the V-Ports are now being exposed to the flow path.

30% Open Position: Shows the plug assembly in the 30% opened position. Now it can clearly be seen that the full V-Port is creating a larger orifice in the flow path. Up to this point, cavitation needs to be dealt with to increase the life expectancy of the valve. The V-port trim ensures that the seating elements are further apart from each other during low flow allowing the cavitation to take place on noncritical components of the valve.

40% Open Position: Shows the plug assembly in the 40% open position. Now it can clearly be seen that the V-Port is completely away from the seat and the flow path is now relatively large. At this point the flow is approaching its medium demand flow rate and the V-Port has little to no function.

Operating Conditions:

These valves are designed to operate in systems with relatively clean media like water or other liquids with a low percentage of suspended solids and chlorides. The valve's operating pH range is 2 - 14 pH.





LFC™_3B Level Control Valve

LFC™_3B Level Control Valve:

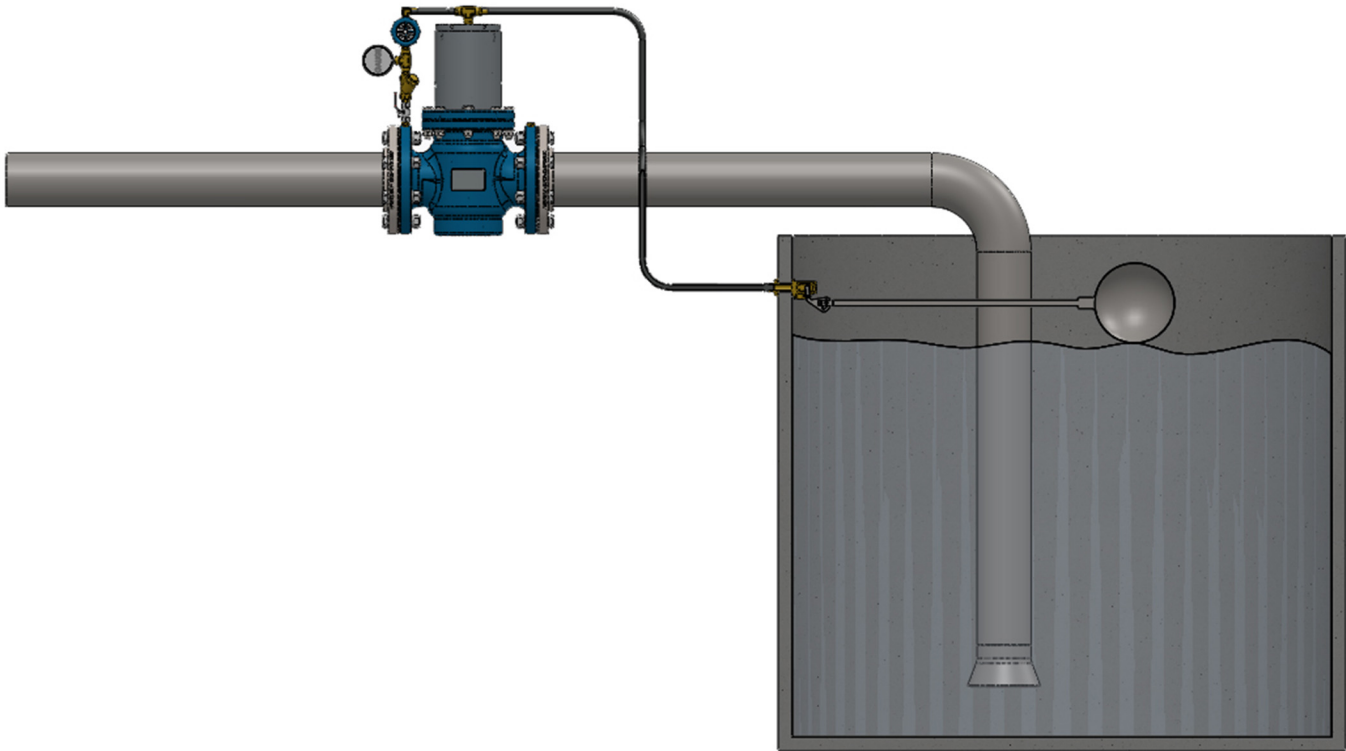

Design & Manufacturing Standards:

The LFC™_3B level control valve has been designed in accordance with various international standards as set out below:

ASME Boilers and pressure vessels design code

ANSI B16.10 ANSI B16.3
ANSI B16.34 ANSI B16.37
ANSI B16.5 ANSI N278.1

Available sizes: DN50 / 2" to DN400 / 16"

Face to face dimensions to ANSI B16.10

Pressure rating: up to 2.5 MPa / 363psi

Available end connections: ANSI B16.5, BS4504, BS10, AS/NZS 4331.1 (ISO 7005-1) DIN, all makes of grooved or ring joint couplings and other as per client's requirement.

